



Diaphragm seals are designed to isolate the sensing element of pressure gauges and pressure switches from process fluids which may be corrosive, viscous, sedimentous and/or with a high temperature. The diaphragm is welded to the upper body, to ensure separation of filling fluid from process medium. Diaphragm faced position permit an accurate and deeper cleaning. Process sizes are ASME/EN 1092 flanged to suit application in pharmaceutical, chemical, petrochemical, water treatment, paper and food process industries.

4.500 - MGS9/5

Working pressure: from 0...15 to 0...6000 psi (from 0...1 to 0...400 bar).

Working temperature: -49...+302°F (-45°C...+150°C.)

Accuracy*: (add to instrument accuracy) ±0,5% for direct mounting; ± 1% for capillary mounting.

Diaphragm, welded to process connection:

AISI 316 L st.st (cod. **4**); Monel 400 (cod. **6**); Hastelloy C276 (cod. **9**).

Flanged process connection: AISI 316 st.s. (cod. **4**); AISI 316L st.s. (cod. **5**); Hastelloy C276 (cod. **9**).

Full-cover version: wetted parts covered with

* at +68°F (20 °C) process temperature (or state when ordering)

Monel 400 (cod. **6FC**); Hastelloy C (cod. **9FC**); Tantalum (cod. **BFC**).

Dimensions : DN 25...80 e PN 2,5...100 EN 1092-1 step seal type B; 1"...3" class 150...1500 as per ASME B16.5 type RF.

UNI-DIN flanges finishing: type B1 (PN 2,5...40) = Ra 3,2...12,5 μm (cod. **RF7**); type B2 (PN 63...100) = Ra 0,8...3,2 μm (cod. **RF8**).

ASME flanges finishing: type RF = Ra 125...250 AARH (cod. **RF3**).

Filling liquid: silicon oil.

ASSEMBLING

All diaphragm seals are mounted on the instruments and fixed by an aluminium protection label. For applications with capillary: shoul diaphragm seal and instrument not be at the same level, instrument adjustment is required). (For use and installation, see data sheet "4")

D - Direct	9 - Capillary AISI304 st.st., AISI304 st.st. armoured, 36.37" max (6 mt max)
T - Cooling extension (O.t. ≥ 100°C)	6 - Capillary AISI316 st.st., AISI316 st.st. armoured, 36.37" max (6 mt max)
1 - Nude capillary AISI304, 36.37" max (6 mt max)	

OPTIONS

B - Silicon liquid "B", process fluid temp. -4°F...+482°F (-20°C...+250°C)
C - Silicon liquid "C", process fluid temp. +68°F...+644°F (+20°C...+340°C)
E - Fluorinated liquid for process fluid temp. from -76°F to +302°F (from -60°C +150°C)
G - Mineral food liquid for process fluid temp. -4°F to +248°F (from -20°C +120°C)
C05 - Helium Test (1)
E30 - NACE MR0103/MR0175 (ISO 15156) (2)
P04 - Dye penetrant test (1)

(1) Available for some excutions pls. consult our technical dep. to check their feasibility.

(2) With Monel 400 or Hastelloy C diaphragm only.

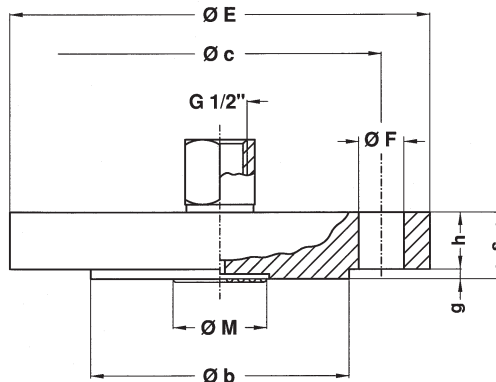

EN 1092 STANDARD

dimensions : mm

DN (1)	PN-bar (1)	Code	E	c	b	g	h	s	N (2)	F	M	Ranges (3)
25	10...16/25...40	QQ0/QS0	115	85	68	2	16	18	4	14	30	0...6
25	63...100	QT0/QU0	140	100	68	2	22	24	4	18	30	0...6
40	10...16/25...40	SQ0/SS0	150	110	88	2	16	18	4	18	40	0...2,5
40	63...100	ST0/SU0	170	125	88	2	24	26	4	22	40	0...2,5
50	10...16	TQ0	165	125	102	2	16	18	4	18	50	0...1
50	25...40	TS0	165	125	102	2	18	20	4	18	50	0...1
50	63	TT0	180	135	102	2	24	26	4	22	50	0...1
50	100	TU0	195	145	102	2	26	28	4	26	50	0...1
80	10...16	VP0/VQ0	200	160	138	2	18	20	8	18	65	0...1
80	25...40	VS0	200	160	138	2	22	24	8	18	65	0...1
80	100	VU0	230	180	138	2	30	32	8	26	65	0...1

ASME STANDARDS

dimensions : inches

DN (1)	Class (1)	Code	E	c	b	g	h	s	N (2)	F	M	Ranges (3)
1"	150	6AA	4,33"	3,13"	2"	0,08"	0,50"	0,58"	4	0,63"	1,18"	0...6
1"	300	6BA	4,92"	3,5"	2"	0,08"	0,63"	0,7"	4	0,75"	1,18"	0...6
1"	600	6DA	4,92"	3,5"	2"	0,28"	0,69"	0,96"	4	0,75"	1,18"	0...6
1"	900...1500	6FA	5,91"	4"	2"	0,28"	1,13"	1,4"	4	1"	1,18"	0...6
1" 1/2	150	AAA	4,92"	3,87"	2,87"	0,08"	0,63"	0,7"	4	0,63"	1,57"	0...2,5
1" 1/2	300	ABA	6,1"	4,5"	2,87"	0,08"	0,75"	0,83"	4	0,87"	1,57"	0...2,5
1" 1/2	600	ADA	6,1"	4,5"	2,87"	0,28"	0,88"	1,15"	4	0,87"	1,57"	0...2,5
1" 1/2	900...1500	AFA	7,09"	4,87"	2,87"	0,28"	1,25"	1,53"	4	1,12"	1,57"	0...2,5
2"	150	BAA	5,91"	4,75"	3,63"	0,08"	0,69"	0,77"	4	0,75"	1,97"	0...1
2"	300	BBA	6,5"	5"	3,63"	0,08"	0,81"	0,89"	8	0,75"	1,97"	0...1
2"	600	BDA	6,5"	5"	3,63"	0,28"	1"	1,28"	8	0,75"	1,97"	0...1
2"	900...1500	BFA	8,46"	6,5"	3,63"	0,28"	1,5"	1,78"	8	1"	1,97"	0...1
3"	150	EAA	7,48"	6"	5"	0,08"	0,88"	0,96"	4	0,75"	2,56"	0...1
3"	300	EBA	8,27"	6,63"	5"	0,08"	1,06"	1,14"	8	0,87"	2,56"	0...1
3"	600	EDA	8,27"	6,63"	5"	0,28"	1,25"	1,53"	8	0,87"	2,56"	0...1
3"	900	EEA	9,45"	7,5"	5"	0,28"	1,5"	1,78"	8	1"	2,56"	0...1
3"	1500	EFA	9,45"	8"	5"	0,28"	1,88"	2,15"	8	1,26"	2,56"	0...1

(1) Other dimensions available on request: pls. refer to Technical Service.

(2) N° holes .

(3) Minimum range available in bar of DS 4...6" (DN 100...150mm) instrument.

"HOW TO ORDER" SEQUENCE

Section	Model material	Connection material	Diaphragm connection	Process	Flange finishing	Instrument connection	Assembling	Options
4	500	4, 6, 9	4, 5, 9 6FC...BFC	QQ0...VU0 6AA...EFA	RF3...RF8	41F - G 1/2 F	D, T 1, 9, 6	B, C, E C05...P04